

THE GENERAL RADIO
EXPERIMENTER

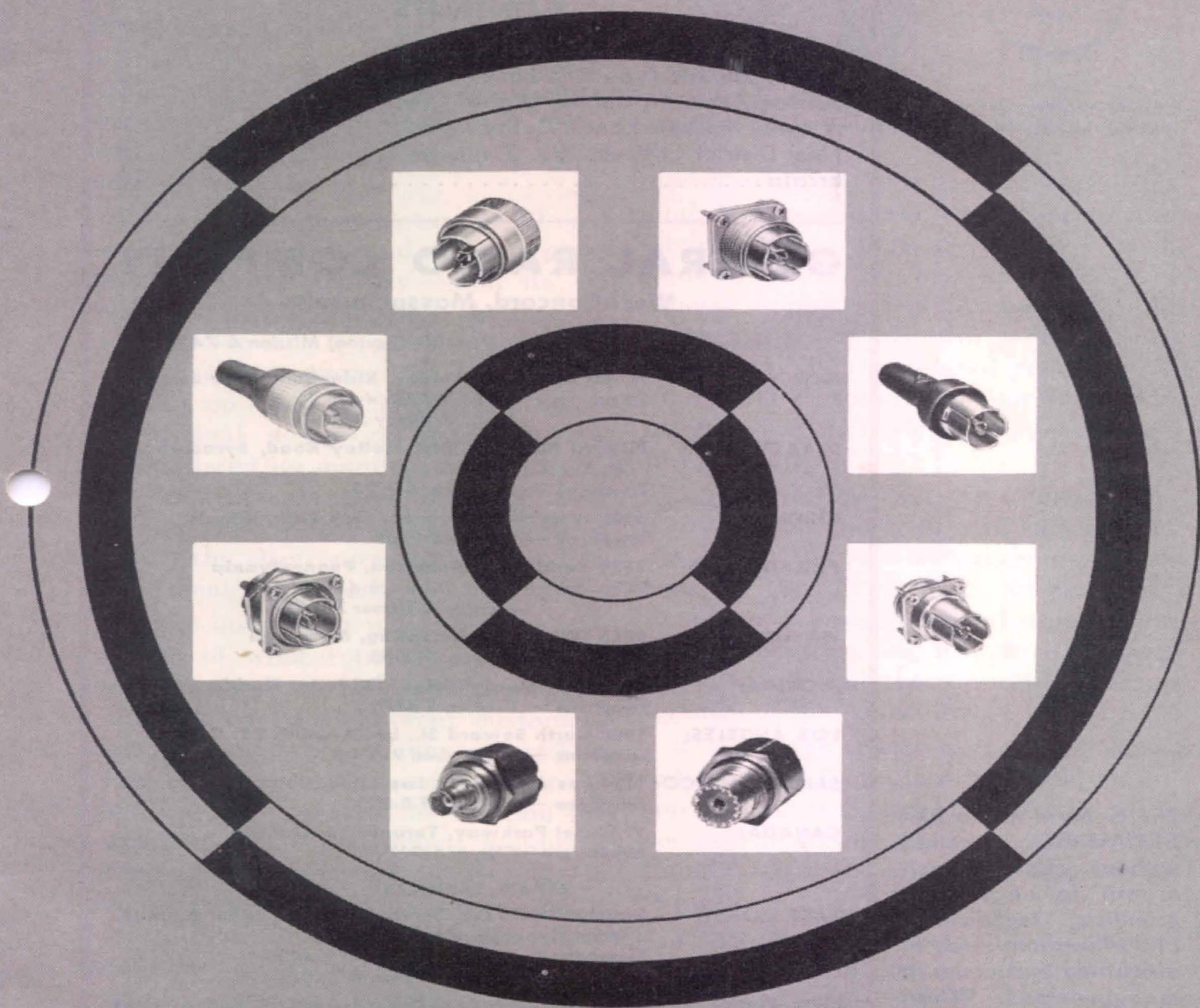

VOLUME 35 No. 10

OCTOBER, 1961

IN THIS ISSUE



**Coaxial Connectors
Digital-to-Analog Converter
Delay Line
New District Offices**

EXPERIMENTER



©1961—GENERAL RADIO COMPANY, WEST CONCORD, MASS., U.S.A.

Published Monthly by the General Radio Company

VOLUME 35 · NUMBER 10

OCTOBER, 1961

CONTENTS

	Page
New and Improved Coaxial Connectors	3
New Tools for Type 874 Locking Connectors	10
Analog Output from the Digital Counter	11
A New, Narrow-Range Delay Line	17
New District Offices	18
Errata	19

GENERAL RADIO COMPANY

West Concord, Massachusetts

Telephone: (Concord) EMerson 9-4400; (Boston) MISSION 6-7400

- NEW YORK:** Broad Avenue at Linden, Ridgefield, New Jersey
Telephone — N. Y., WOrth 4-2722
N. J., WHitney 3-3140
- SYRACUSE:** Pickard Building, East Molloy Road, Syracuse 11,
N. Y.
Telephone — GLenview 4-9323
- CHICAGO:** 6605 West North Avenue, Oak Park, Illinois
Telephone — VIlIage 8-9400
- PHILADELPHIA:** 1150 York Road, Abington, Pennsylvania
Telephone — Phila., HANcock 4-7419
Abington, TURner 7-8486
- WASHINGTON:** 8055 13th St., Silver Spring, Maryland
Telephone — JUNiper 5-1088
- FLORIDA:** 113 East Colonial Drive, Orlando, Florida
Telephone — GARden 5-4671
- LOS ANGELES:** 1000 North Seward St., Los Angeles 38, Calif.
Telephone — HOLlywood 9-6201
- SAN FRANCISCO:** 1186 Los Altos Ave., Los Altos, Calif.
Telephone — WHitecliff 8-8233
- CANADA:** 99 Floral Parkway, Toronto 15, Ontario
Telephone — CHerry 6-2171

REPAIR SERVICES

- EAST COAST:** General Radio Co., Service Dept., 22 Baker Avenue,
West Concord, Mass.
Telephone — Concord, EMerson 9-4400
Boston, MISSION 6-7400
- NEW YORK:** General Radio Co., Service Dept., Broad Ave. at
Linden, Ridgefield, New Jersey
Telephone — N. Y., WOrth 4-2722
N. J., WHitney 3-3140
- MIDWEST:** General Radio Co., Service Dept., 6605 West North
Ave., Oak Park, Illinois
Telephone — VIlIage 8-9400
- WEST COAST:** General Radio Co., Service Dept., 1000 North
Seward Street, Los Angeles 38, Calif.
Telephone — HOLlywood 9-6201
- CANADA:** Bayly Engineering, Ltd., First St., Ajax, Ontario
Telephone — Toronto EMpire 2-3741

The General Radio EX-
PERIMENTER is mailed
without charge each
month to engineers,
scientists, technicians,
and others interested in
electronic techniques in
measurement. When
sending requests for
subscriptions and ad-
dress-change notices,
please supply the fol-
lowing information:
name, company ad-
dress, type of business
company is engaged
in, and title or position
of individual.

NEW AND IMPROVED COAXIAL CONNECTORS

LOWER VSWR—NEW LOCKING TYPES—LOWER LEAKAGE

The TYPE 874 Coaxial Connector* has found increasingly wide acceptance each year since its introduction in 1948. It is a unique device, designed primarily for use in measurement systems and compatible, through a comprehensive line of low-reflection adaptors, with all other commonly used coaxial connectors.

Its hermaphroditic feature — all connectors are identical and any one plugs directly into any other — and its excellent VSWR have made it the basis of an extensive line of measuring instruments and accessories for use at frequencies up to about 5000 Mc. Because the original design of the connector contemplated its manifold applications, these instruments have provided outstanding performance and versatility both in the electronics industry and in educational institutions.

To the instrument manufacturer, the problem of what type of coaxial connector to supply on his product has been a difficult one, for different customers want different types of connectors. The TYPE 874, with its associated line of adaptors, has provided the solution for a growing list of instrument manufacturers. New connector and adaptor designs, described in this article, make this solution much more attractive and more satisfactory than ever before.

The use of several millions of these connectors in a wide variety of applications at frequencies ranging from dc to several thousand megacycles per second

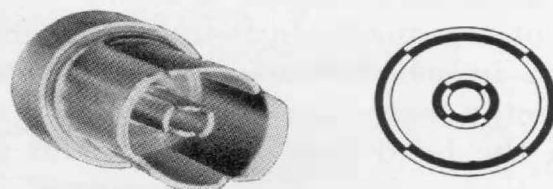

Figure 1. (Left) Type 874 Coaxial Connector. (Right) Cross section of two connectors plugged together.

has clearly demonstrated the versatility and soundness of the basic concept and design. Not surprisingly, however, such widespread usage has also indicated where improved performance would further enhance the utility of the connector and has generated requests for additional features. The improvements most frequently requested have centered in four areas.

1. The desire for a permanent connection is obviously in conflict with the desire for quick-connect/disconnect feature of the TYPE 874. Nevertheless, many users have expressed a desire for a permanent locking feature while still retaining all the other desirable characteristics of the connector.

2. Although rf leakage is of the same order as that found in other widely used connectors, the usefulness of the connectors in certain critical applications would be increased if the leakage were reduced.

3. Although VSWR for these connectors has been lower than that of most other basic connectors up to frequencies of the order of 4000 or 5000 Mc, a reduction in the VSWR and an even wider frequency range would naturally be welcomed. The VSWR should also be closely reproducible, regardless of how

*U. S. Patent No. 2,548,457.

many times a pair of connectors is plugged together and unplugged.

4. In the original design, some loosening of the connector assembly could occur with prolonged use as a result of cold flow of the insulating support bead. A design in which the secureness of the connector assembly does not depend upon the bead compression would provide more rigid and permanent mechanical assemblies.

An active and continuous development program in design, manufacturing technique, and quality control has been carried on for several years, with particular emphasis on the areas mentioned above. The results of this program to date are detailed below, wherein the new locking version of the connector is described, as well as the improved performance and reliability of both the locking and the non-locking versions. Included in the expanded line are also locking adaptors to other types of connectors.

GENERAL IMPROVEMENTS

Minor revisions in dimensions, closer tolerances, improved tooling, and a particularly rigorous program of statistical quality control have extended the

range of satisfactory operation to about 7000 Mc, improved reliability, reduced VSWR variation from unit to unit, and improved the mechanical feel and ease of use of the connector. The most significant design change, however, provides a secure metal-to-metal joint in the outer conductor assembly, eliminating dependence on compression of the polystyrene bead which now serves only to support the inner conductor. Although the bead is still put under compression when the connector is assembled, this is merely to ensure that the bead stays in place. Figure 2 shows this construction.

Needless to say, one of the important criteria for any design change was that the improved connector be compatible electrically and mechanically with connectors already in use. Any TYPE 874 connector, regardless of vintage, will connect satisfactorily to any other TYPE 874 connector.*

THE NEW LOCKING CONNECTOR

The new locking version of the TYPE 874 complements the non-locking, quick-

*The only exception is that a new locking connector will not mate with a TYPE 874-P Panel Connector because of its long shroud. This type of connector is now replaced by the TYPE 874-PB and -PL Panel Connectors.

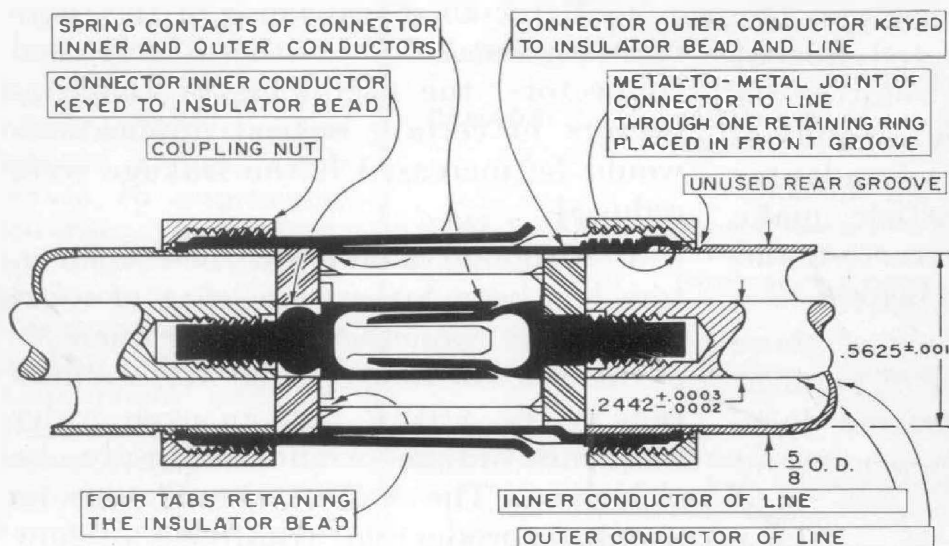
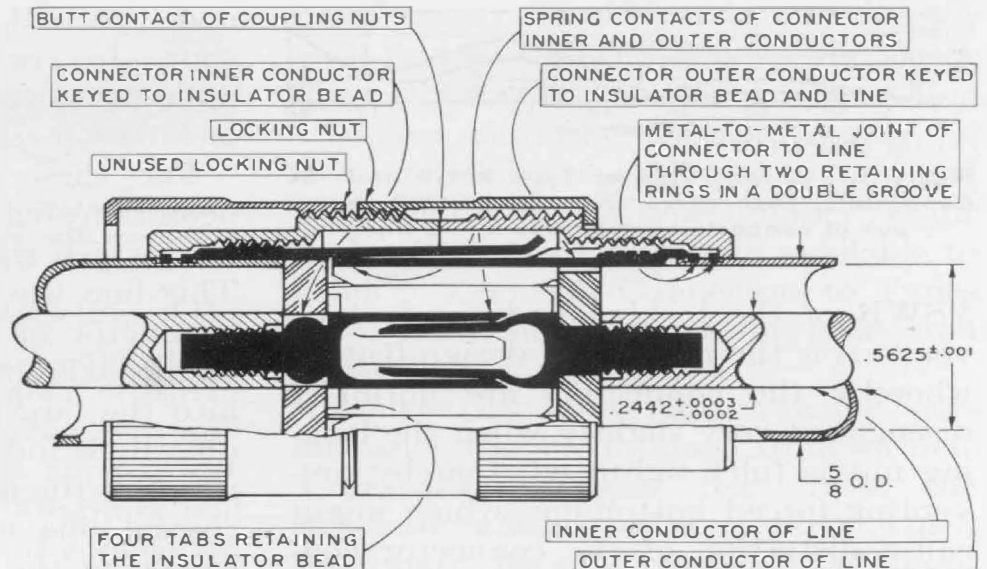

Figure 2. Sectional view of improved non-locking connector. The back edge of the connector outer conductor is drawn up against the retaining ring when the coupling nut is fully tightened. The beveled inside surface of the coupling nut forces the split retaining ring solidly against the bottom of the groove in the outer conductor of the line, and thus a solid metal-to-metal joint is obtained between the outer conductors of the connector and line. The insulating bead is held securely in place by four small tabs which sink into the insulator as the coupling nut is tightened.



Figure 3. Sectional view of the new locking connector. The solid metal-to-metal joint between the connector and the line on which it is mounted is obtained by clamping a pair of retaining rings against a ridge between two grooves in the outer conductor of the line. As the coupling nut is tightened, the two rings are forced against the ridge by the back edge of the connector outer conductor and a shoulder inside the coupling nut.



connect/disconnect type by providing a rigid connection for semi-permanent installations. These are now in production, and they offer the following features:

1. Provision for rigid mechanical coupling (at the user's option, connectors will mate without locking).
2. Ease of use.
3. Retention of the hermaphroditic feature so that any two connectors will mate and lock together.
4. Compatibility with existing non-locking TYPE 874 connectors.
5. Retention of the quick-connect/disconnect feature when the locking feature is not wanted.

The last two items are particularly significant. The ability to connect together a non-locking and a locking type (and to use the lock or not to use it as one chooses) results in a coaxial connector system of extraordinary flexibility and versatility.

Figure 3 shows in detail how the above results have been achieved. The coupling nut, which fastens the outer connector to the coaxial line, has been modified and a locking nut added. When two locking TYPE 874's are plugged together, the locking nut of either can be

screwed onto the coupling nut of the other to lock the connection. The locking nut on the second connector is backed off to a storage position. When the two connectors are mated and locked, the coupling nuts are butted together and provide a stop, eliminating the possibility of damage to the inner or outer conductor through overtightening.

The solid metal-to-metal joint mentioned previously is an integral and, in fact, essential part of the design of the locking connector.

The new locking connectors are available for use on air lines, cables, and panels. Locking cable connectors are available in five sizes to accommodate various popular coaxial cables. Locking panel connectors are available in both recessed and nonrecessed versions, each having four cable sizes and one wire-lead type.

ELECTRICAL PERFORMANCE

Standing-Wave Ratio

VSWR characteristics of typical TYPE 874-BL Locking Connectors and TYPE 874-B Connectors taken from a current production run are shown in Figure 4.

The slight difference between the

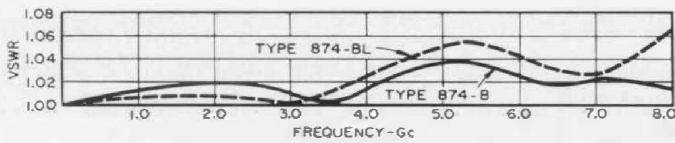

Figure 4. Typical VSWR of Type 874-B and -BL Connectors. Each curve shows the VSWR that a pair of connectors introduces into a line.

VSWR of the locking and non-locking versions is the result of a design feature whereby the connectors are normally disengaged very slightly when the locking nut is fully tightened, thereby preventing forced bottoming, which might cause distortion of the connector contacts. The VSWR characteristic plotted corresponds to the statistically maximum disengagement of the connectors.

In addition to the improved mechanical features of the locking connector, the rf leakage has been greatly reduced, owing to the additional shielding provided by the coupling and locking nuts. The leakage from typical sets of the TYPE 874-BL Locking Connectors is shown as a function of frequency in Figure 5. The leakage characteristics of the non-locking TYPE 874 Connector

and Types BNC and N connectors are shown for comparison. An improvement of approximately 50 db over the non-locking version is shown.

For these measurements, the connectors tested were inserted in a coaxial line, which was terminated in 50 ohms. This line was in turn made the center conductor of a larger, terminated, 50-ohm coaxial line, and the power leaking into the larger line was measured. The db values indicated in Figure 5 are the ratios of the power input to the internal coaxial line to the leakage power absorbed in the termination of the larger line.

NEW AND IMPROVED ADAPTORS

Obviously, the TYPE 874 Adaptors were designed to adapt TYPE 874 Connectors to other coaxial connectors, but equally important is their ability to interconnect different types of military connectors without introducing major reflections (see Figure 6). The more types of connectors involved, the more attractive are the TYPE 874 Adaptors. As an illustration, suppose that the

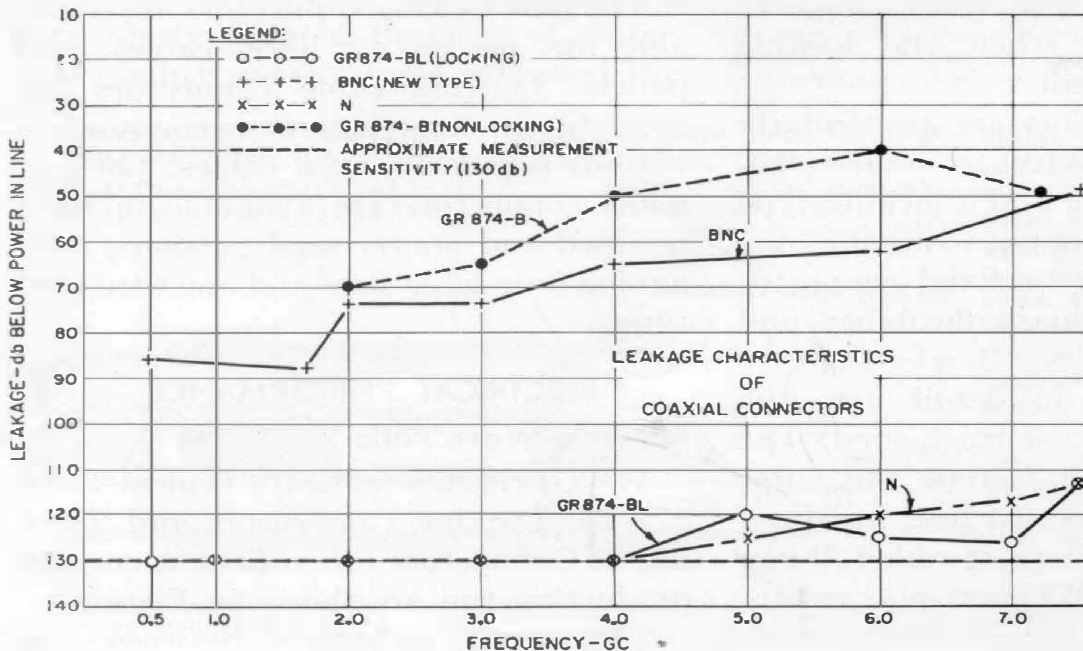

Figure 5. Leakage characteristics of several types of coaxial connectors.

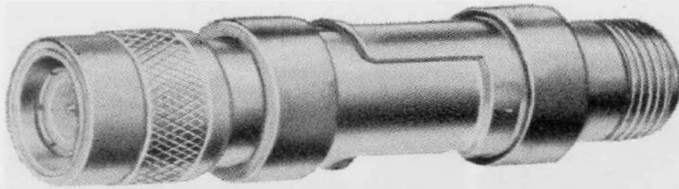

Figure 6. Type 874-QCP and -QNJA Adaptors plugged together. This assembly will connect a Type C jack to a Type N plug.

equipment in a laboratory contained the Types BNC, C, HN, LT, N, and UHF plugs and jacks. The number of direct adaptors needed to interconnect any connector with any other type is 60, while only 12 TYPE 874 Adaptors will do the same job (and permit connection to TYPE 874 Connectors as well). Not only is there an economy in adaptors, but, since many of the needed 60 direct adaptors do not exist, a pair of intermediate TYPE 874 Adaptors often comprises the most direct means available.

The performance of standard non-locking adaptors has been improved by redesign that incorporates the basic connector improvements already discussed. In addition, most adaptors have been shortened, and at the same time the performance of the "military" end of the connector has been improved. In

most cases, the VSWR of an adaptor with its two connectors is as low as, or lower than, that of the corresponding standard military connector (see Fig. 7).

A new, shortened adaptor is identified by a final A in the type number. Eight such adaptors are presently available to connect TYPE 874 Connectors to Types BNC, HN, and LC plugs and jacks, and Types C and N plugs.

Longer life and more reliable performance will be obtained from all new TYPE 874 Adaptors than from the standard military connectors to which they mate, because hardened beryllium copper (or, in some types, phosphor bronze) is used in the plug contacts instead of brass.

NEW LOCKING ADAPTORS

To the long list of available TYPE 874 Adaptors have been added several popular types incorporating the new locking connector. The locking feature is now available in six of the more popular adaptors. Each of these adaptors contains locking TYPE 874 Connector and a Type BNC, C, N, SC, TNC, or UHF

Figure 7. Typical VSWR introduced in line by pairs of Type 874 Adaptors plugged together.

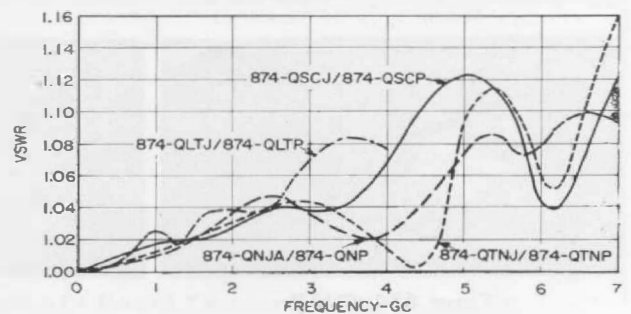
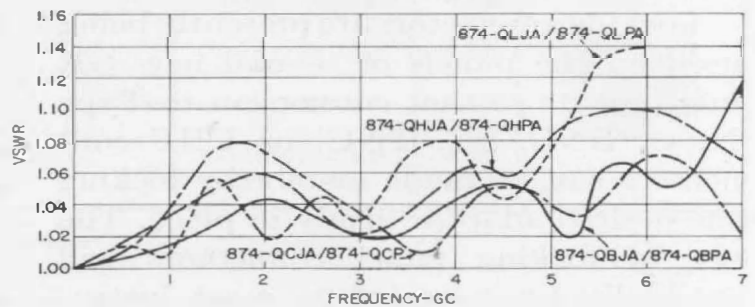
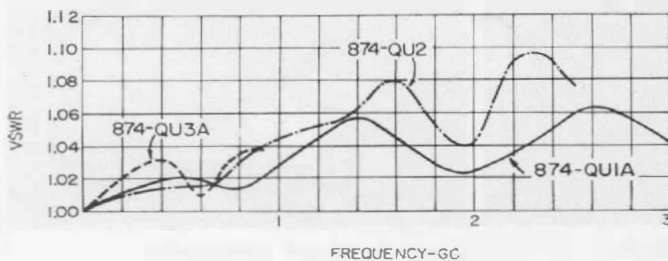

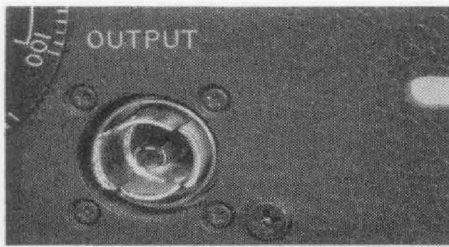

Type 874-PRL

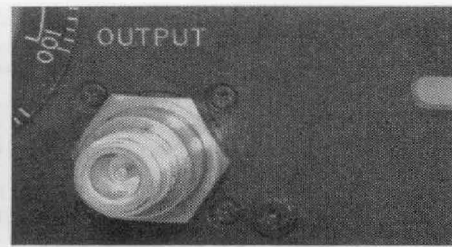

Type 874-QNJL

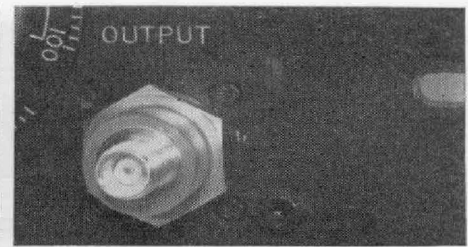

Type 874-QTNJL

Figure 8. A recessed panel connector, Type 874-PRL (shown at left), is converted to other connector types by the addition of adaptors, as shown in the photographs above and in those at the foot of the page.

jack. Thus an instrument equipped with TYPE 874 Locking Panel Connectors can be quickly converted to any of these military connector systems by means of rigid, semi-permanent adaptors as shown in Figure 8.

The quick-conversion capability offers to the instrument manufacturer a basic panel connector that can be quickly adapted to meet individual customer specifications for various coaxial connectors. Furthermore, the user of an instrument equipped with the locking panel connector can readily change from one type of connector to another. If the instrument is equipped with the new recessed locking panel connectors, the conversion is especially neat, for the locking adaptors extend only about an inch in front of the panel.

Locking connectors are presently being used on the panels of several new GR instruments so that conversion to Type N, C, BNC, SC, TNC, or UHF connectors can be made merely by locking the desired adaptor firmly in place. The use of locking panel connectors will gradually be extended to most instru-

ments in the GR line. Most components (tees, lines, attenuators, pads, etc.) have been, or will be, modified to permit the use of either locking or non-locking connectors.

The older TYPE 874 Connectors on these latter components cannot be directly replaced with the locking type, since an additional groove is required and the groove position is different. Components with non-locking connectors having the new construction can be identified by an unused groove in the outer conductor which appears directly behind the coupling nut.

Increased acceptance of the TYPE 874 Connector has already resulted from the increased versatility and the improvement in performance. This connector is well on the way to the same universal acceptance that has been accorded the banana plug, first introduced in the United States by General Radio in 1924. The development program which produced these design changes is continuing with emphasis on improvement of the cable connectors and on further reductions of VSWR.

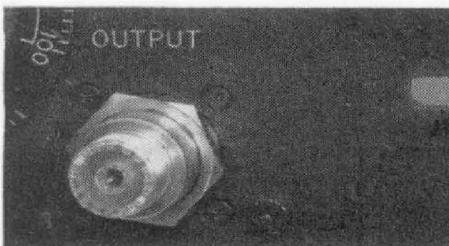

Type 874-QUJL

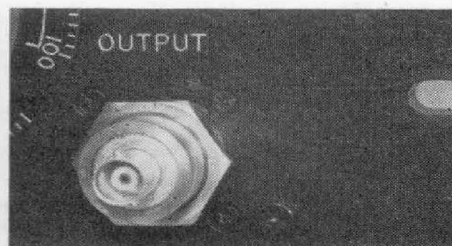

Type 874-QBJL

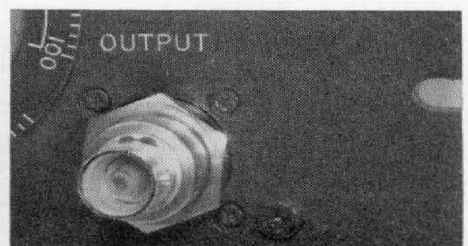

Type 874-QCJL



CONNECTORS

	Type	Fits	Code Word	Price*	
Basic Connectors	874-B	50-ohm Rigid Air Line	COAXBRIDGE	\$1.60	See Fig. 1
	874-BL	50-ohm Rigid Air Line (locking)	COAXYPIPIIT	2.50	
Cable Connectors	874-C	874-A2 Cable	COAXCABLER	2.30	
	874-C8	RG-8/U Cable	COAXCORDER	2.30	
	874-C9	RG-9/U, RG-116/U Cables	COAXCAMMER	2.30	
	874-C58	874-A3, RG-29/U, RG-55/U, RG-58/U, RG-58A/U Cables	COAXCALLER	2.30	
	874-C62	RG-59/U, RG-62/U Cables (nonconstant impedance)	COAXCANDOR	2.30	
Cable Connectors—Locking	874-CL	874-A2 Cable	COAXYROBIN	3.50	
	874-CL8	RG-8/U Cable	COAXPARROT	3.50	
	874-CL9	RG-9/U, RG-116/U Cables	COAXYJUNCO	3.50	
	874-CL58	874-A3, RG-29/U, RG-55/U, RG-58/U, RG-58A/U Cables	COAXYSNIPE	3.50	
	874-CL62	RG-59/U, RG-62/U Cables (nonconstant impedance)	COAXYSWIFT	3.50	
Panel Connectors—Flanged	874-PB	874-A2 Cable	COAXAPPLER	3.20	
	874-PB8	RG-8/U, RG-9/U, RG-116/U Cables	COAXBATHER	3.20	
	874-PB58	874-A3, RG-29/U, RG-55/U, RG-58/U, RG-58A/U Cables	COAXABATER	3.20	
	874-PB62	RG-59/U, RG-62/U Cables (nonconstant impedance)	COAXBARKER	3.20	
Panel Connectors—Locking	874-PL	874-A2 Cable	COAXYFINCH	3.75	
	874-PL8	RG-8/U, RG-9/U, RG-116/U Cables	COAXYVIREO	3.75	
	874-PL58	874-A3, RG-29/U, RG-55/U, RG-58/U, RG-58A/U Cables	COAXTHRUSH	3.75	
	874-PL62	RG-59/U, RG-62/U Cables (nonconstant impedance)	COAXTOUCAN	3.75	
	874-PLT	Wire Lead	COAXWILLET	3.75	
Panel Connectors—Locking, Recessed	874-PRL	874-A2 Cable	COAXYGOOSE	4.00	
	874-PRL8	RG-8/U, RG-9/U, RG-116/U Cables	COAXCONDOR	4.00	
	874-PRL58	874-A3, RG-29/U, RG-55/U, RG-58/U, RG-58A/U Cables	COAXCURLIEW	4.00	
	874-PRL62	RG-59/U, RG-62/U Cable (nonconstant impedance)	COAXAVOCET	4.00	
	874-PRLT	Wire Lead	COAXMERLIN	4.00	

*For quantities of 1 to 99; prices for larger quantities on request.

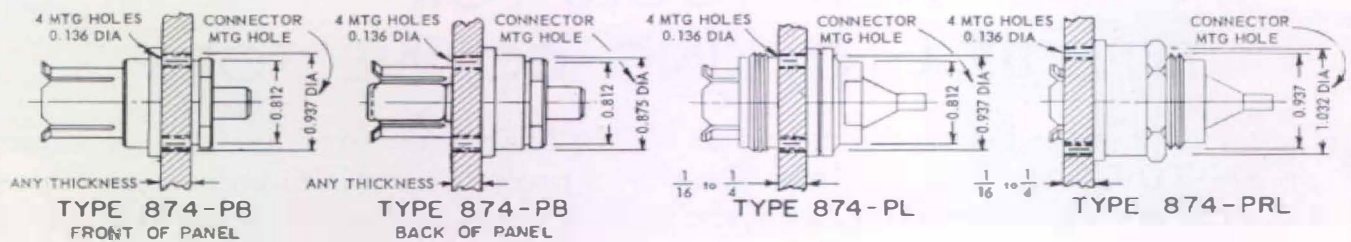

Figure 9. Mounting dimensions for Type 874 Panel Connectors.

ADAPTORS

	Type*	Connects Type 874 to . . .	Code Word	Price	
TO TYPE BNC	874-QBJA	BNC Plug	COAXBOGGER	\$4.75	
	874-QBJL	BNC Plug (locking 874)	COAXCASHEW	5.75	
	874-QBPA	BNC Jack	COAXBUNNER	5.25	
TO TYPE C	874-QCJA	C Plug	COAXCOGGER	5.50	
	874-QCJL	C Plug (locking 874)	COAXYPECAN	6.50	
	874-QCP	C Jack	COAXCUFFER	6.25	
TO TYPE HN	874-QHJA	HN Plug	COAXHAWSER	6.00	
	874-QHPA	HN Jack	COAXHANGER	7.50	
TO TYPE LC	874-QLJA	LC Plug	COAXLITTER	12.00	
	874-QLPA	LC Jack	COAXLUGGER	20.00	
TO TYPE LT	874-QLTJ	LT Plug	COAXLAGGER	20.00	
	874-QLTP	LT Jack	COAXLOBBER	25.00	
TO TYPE N	874-QNJA	N Plug	COAXNAGGER	5.00	
	874-QNJL	N Plug (locking 874)	COAXWALNUT	6.00	
	874-QNP	N Jack	COAXNUTTER	5.00	
TO TYPE SC	874-QSCJ	SC Plug (Sandia)	COAXCOSTER	9.00	
	874-QSCJL	SC Plug (Sandia) (locking 874)	COAXALMOND	10.00	
	874-QSCP	SC Jack (Sandia)	COAXCASHER	9.00	
TO TYPE TNC	874-QTNJ	TNC Plug (Sandia)	COAXTUNNER	6.50	
	874-QTNJL	TNC Plug (Sandia) (locking 874)	COAXYHAZEL	7.50	
	874-QTNP	TNC Jack (Sandia)	COAXTUSKER	6.50	
TO TYPE UHF	874-QUJ	UHF Plug	COAXYUNDER	5.00	
	874-QUJL	UHF Plug (locking 874)	COAXYBEECH	6.00	
	874-QUP	UHF Jack	COAXPUPPER	5.00	
TO TYPE 274	874-Q2	274 Plug or Jack	COAXTIPPER	5.50	
	874-Q9	938 Binding Posts	COAXPOSTER	6.00	
	874-QN6	274-NO Patch Cord	COAXCHOSER	3.75	
TO UHF RIGID LINE	874-QU1A	7/8-in. 50Ω UHF Rigid Line, RG-155/U (EIA TR-134)	COAXYUMBER	35.00	
	874-QU2	1 5/8-in. 50Ω UHF Rigid Line, RG-153/U (EIA TR-134)	COAXYUSHER	80.00	
	874-QU3A	3 1/8-in. 50Ω UHF Rigid Line, RG-154/U (EIA-TR134)	COAXYULTRA	135.00	

*In adaptor type numbers, a J indicates that the adaptor contains a jack and a Type 874 Connector; a P indicates that the adaptor contains a plug and a Type 874 Connector. For example, a Type 874-QUP Adaptor contains a UHF plug and a Type 874 Connector, and will therefore adapt a Type 874 to a UHF jack.

NEW TOOLS FOR TYPE 874 LOCKING CONNECTORS

Three tools have been added to the Type 874-TOK Tool Kit to help in the installation of locking connectors on air lines and other components. In such installations, it may not be possible to

slide back the coupling nut (see Figure 3 in preceding article) enough to expose the retaining-ring grooves because of changes in diameter of the outer conductor or various other obstructions; setting

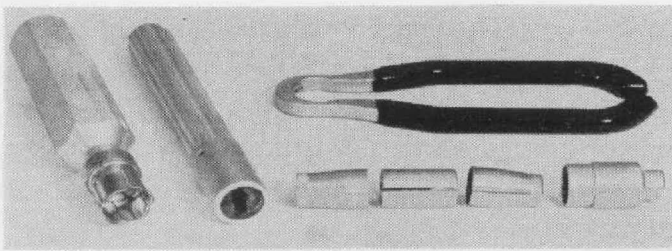

Figure 1. Type 874-TOK Tool Kit consisting of (left) an outer-conductor wrench and an inner-conductor wrench, (right, top) a coupling-nut wrench, and (right, bottom) ring installation tools.

the rings into the grooves can then be difficult, especially inasmuch as the rear ring must pass over the front groove on the way to its position. The three new tools make installation of the retaining rings a simple matter whether grooves

are exposed or not. The ring is first placed on one of two cylindrical loaders, depending on which groove it is destined for. The loader is then placed over the outer conductor and the third tool, a cylindrical pusher, is placed over the loader and used to push the ring off the loader and into place in the groove.

The other tools in the TYPE 874-TOK Tool Kit, described in the May, 1960 *Experimenter*, are an inner-conductor wrench to hold and install the insulating bead and the inner connectors, and an outer-conductor wrench and a coupling-nut wrench to install the outer connector and to tighten the coupling nut.

Type		Code Word	Price
874-TOK	Tool Kit	COAXKIT7EN	\$20.00

ANALOG OUTPUT FROM THE DIGITAL COUNTER

Digital counters offer high precision and accuracy combined with a degree of operating convenience for visual readout that is not easily obtained by other means. In many applications, however, it is desirable to have permanent records. Digital printers are useful for this purpose when individual point-by-point measurements are made, but, when the data vary continuously, the printed information must be evaluated line by

line. Unless automatic equipment can be used, this process is tedious and slow.

For instance, if the frequency of a quartz-crystal oscillator as a function of temperature is to be determined, a direct analog plot of frequency versus temperature is usually wanted. Figure 2 shows this information in both forms; the analog curve and the printed data. The curve takes only seconds to evaluate, while little can be deduced from



Figure 1. Panel view of the Type 1134-A Digital-to-Analog Converter.

the printed figures without manual plotting. In addition, the temperature values corresponding to individual printed lines are easily available in analog form (from a thermocouple) while conversion into digital form (to print along with the other data) is both cumbersome and costly.

Although no analog output can be accurate to 6 or more places, the analog accuracy is quite adequate for incremental measurements. Operating from a digital counter, the analog system can always be used to interpolate. If the counter displays 8 figures, the analog output can be made to represent any two or three of the 8.

The crystal oscillator frequency in Figure 2 varies only by a few parts per million over the temperature range. The full-scale sensitivity is 20 ppm and with 0.1% incremental accuracy, 2×10^{-8} can be observed. Note that the digital record does not provide higher accuracy or resolution; the first five figures re-

main constant and can be taken as "a priori" knowledge. There really is no need to record them more than once, which can be done manually. Usually, the increments are the only information of interest.

Where the information varies rapidly, mechanical printers are not able to follow the changes. Most are limited to less than 10 lines per second. The cost of higher speed printers is prohibitive for most applications. The analog recorder, on the other hand, can plot curves with much higher speed. Digital-to-analog conversion can be very fast and recorders with better than 1-ke bandwidth are available. Thus, information can be recorded much faster than with a mechanical printer. A typical example is the measurement of short-term stability of oscillators. Samples as short as .01 and .001 second are of interest and the information is collected at a rate approaching 100 or 1000 samples per second. Figure 3 shows the short-term stability

Figure 2. Frequency-vs-temperature characteristic of 5-Mc crystal. Full scale for analog curve was 100 cps, each minor division 1 cps. Only the significant part of the analog record (from 4998420.0 to 4998460.0) is reproduced here. Gate time was 10 seconds. The digital record shown corresponds to the marked section of the curve between 43.3°C and 56.5°C.

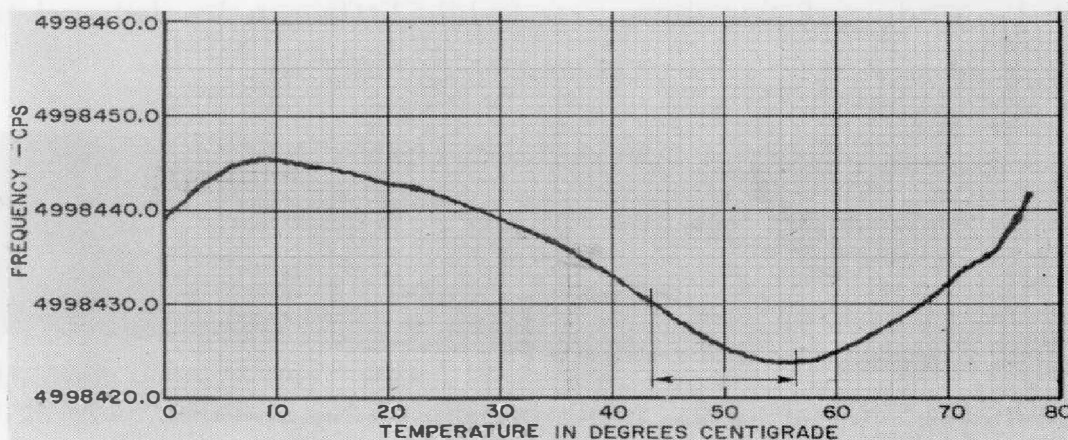

4998423.00
4998423.07
4998423.15
4998423.23
4998423.31
4998423.39
4998423.47
4998423.55
4998423.63
4998423.71
4998423.79
4998423.87
4998423.95
4998424.03
4998424.11
4998424.19
4998424.27
4998424.35
4998424.43
4998424.51
4998424.59
4998424.67
4998424.75
4998424.83
4998424.91
4998424.99
4998425.07
4998425.15
4998425.23
4998425.31
4998425.39
4998425.47
4998425.55
4998425.63
4998425.71
4998425.79
4998425.87
4998425.95
4998426.03
4998426.11
4998426.19
4998426.27
4998426.35
4998426.43
4998426.51
4998426.59
4998426.67
4998426.75
4998426.83
4998426.91
4998426.99
4998427.07
4998427.15
4998427.23
4998427.31
4998427.39
4998427.47
4998427.55
4998427.63
4998427.71
4998427.79
4998427.87
4998427.95
4998428.03
4998428.11
4998428.19
4998428.27
4998428.35
4998428.43
4998428.51
4998428.59
4998428.67
4998428.75
4998428.83
4998428.91
4998428.99
4998429.07
4998429.15
4998429.23
4998429.31
4998429.39
4998429.47
4998429.55
4998429.63
4998429.71
4998429.79
4998429.87
4998429.95
4998429.99
4998430.00

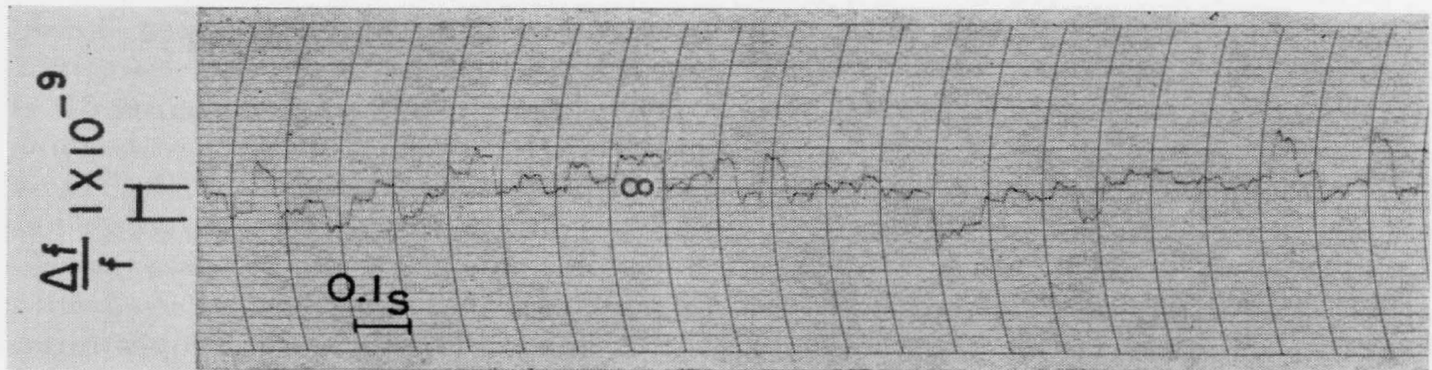

Figure 3. High-speed record of the short-term stability of two GR Type 1113-A Standard-Frequency Oscillators. The 5-Mc outputs are multiplied to 1 Gc each, and the frequency is adjusted for a 105-cycle beat, whose period is recorded. Sampling rate is about 100 samples per second with an averaging time of about 0.01 second. Over-all bandwidth of the measuring system was over 120 cps.

for .01-second samples of a pair of GR TYPE 1113-A Oscillators. The information is collected at the rate of 100 samples per second, far beyond the speed of mechanical printers.

Until recently a digital printer was necessary for mechanical conversion of digital input to analog output, but the introduction of digital counters with storage facilities¹ has made possible the use of electronic conversion. This has reduced the cost of analog recording well below that of digital printing.

In conventional counters the result of the measurement is displayed intermittently. While the counter is accumulating information, the decade states vary continuously, and information to be printed or plotted is available only during each display time. (Some scheme might be used to disconnect the recorder during counting time, but then the recorder would return to zero each time.) Figure 4 shows the analog output obtained from conventional decades. A frequency of about 345 cps is counted for 10 seconds and displayed for 5 seconds. The analog output is derived from the

last three digits of the counter. The zero on the recorder corresponds to 300 cps, the full scale to 400 cps. Note that the analog output during the counting time varies from zero to full scale several times. Usable information is plotted during display time only.

Storage counters, on the other hand, have completely separated storage decades. At the end of each counting interval the data are transferred from

Figure 4. Analog output from 3 conventional decades. Usable information is available during display time only. Gate time was 10 seconds.

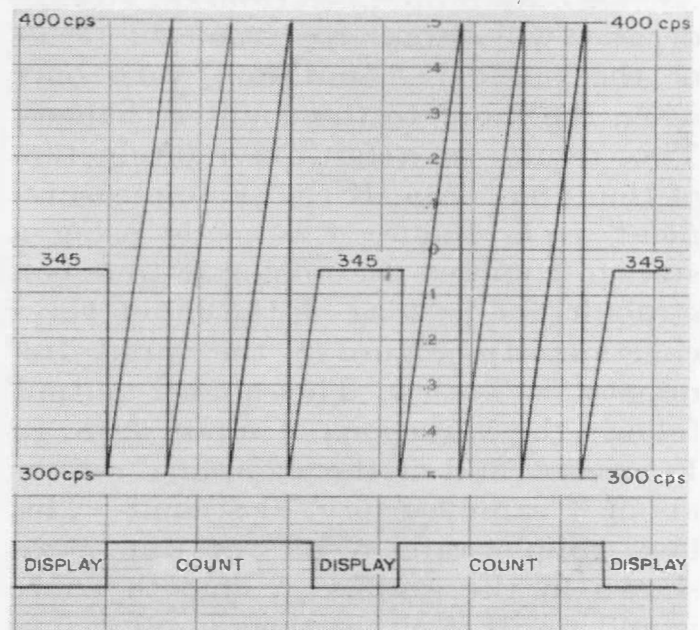

¹R. W. Frank and H. T. McAleer, "A Frequency Counter with a Memory and with Built-In Reliability," *General Radio Experimenter*, 35, 5, May, 1961.

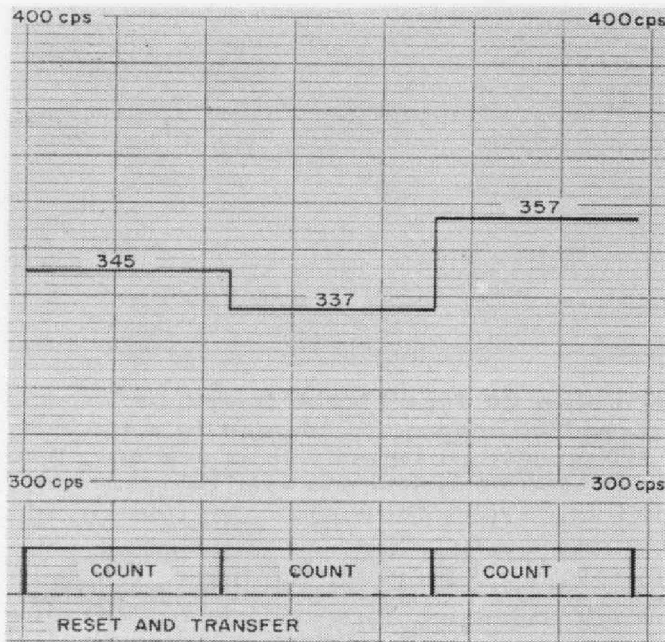

Figure 5. Analog output from 3 storage decades. The output is the result of the previous count.

the counting decades into storage. The counting decades immediately resume counting, and at the end of the next counting interval the new data are transferred again. The information in the storage decades changes only at the transfer time (at the end of each counting interval) and only if the result of the last count is different from the preceding one. Analog output obtained from the storage decades will always represent the result of the previous count and vary only when the input to the counter changes. This results in a faithful reproduction of the input data. If the same measurement as in Figure 4 is made using a storage counter, the analog output is a straight line as long as the input stays constant. In Figure 5 the input frequency is varied. The analog output follows the variations of input data. In Figures 4 and 5 the sampling rate is about 1 sample every 10 seconds. This low sample rate results in the steps shown in the graphs. A smooth curve would result if either the sampling rate

were made higher or the paper slowed down.

These advantages have been realized in the GR TYPE 1130-A Digital Time and Frequency Meter, and the TYPE 1134-A Digital-to-Analog Converter has been designed as a companion instrument. This converter can be used with other digital equipment if proper input logic voltage levels and weighting are available (see specifications). The important features of this instrument are its accuracy and stability of 0.1% and its high conversion speed of over 1 kc. It can be used to full advantage either with precision recorders or XY plotters of 0.1% accuracy or with high-speed recorders to beyond 1 kc.

CIRCUIT DESCRIPTION

The input signals are obtained from the four storage decades of the counter. A digit-selector switch permits selection of the first three, or the last three, or the last two digits to be recorded. If three digits are recorded, the output increments are 0.1% each. For two digits, the increments are 1% each. The output is either 1 ma for galvanometer recorders, or 100 mv for potentiometer recorders.

Principles of Operation

Figure 6 is a simplified schematic diagram of the converter. Twelve input lines (4 for each decade) connect the electronic switches S_1 - S_{12} to the flip-flops in the counter's storage decades. The nominal input voltages are +65 v for a binary 1 and +185 v for a binary 0. For a decade in state 9 (decimal) all four flip-flops are in binary state 1 (+65) and for decimal 0 all flip-flops are in binary state 0 (+185). Each of the electronic switches, S_1 - S_{12} , connects the associated output resistor (weighting re-



sistor) to 0 for a +185-v input (binary 0) and to a very stable voltage, E, for +65-v input (binary 1).

Assume that the recorder has zero impedance and a 1-ma full-scale sensitivity and that the voltage E is -30 v. When S₁-S₁₂ are in the "on" position, the output is made up of the following currents:

S ₁	100 μa	
S ₂	200 μa	100's decade
S ₃	400 μa	Total — 900 μa
S ₄	200 μa	
<hr/>		
S ₅	10 μa	
S ₆	20 μa	10's decade
S ₇	40 μa	Total — 90 μa
S ₈	20 μa	
<hr/>		
S ₉	1 μa	
S ₁₀	2 μa	1's decade
S ₁₁	4 μa	Total — 9 μa
S ₁₂	2 μa	

The sum of all branch currents is 999 μa.

If the impedance of the recorder is not small compared with the impedance of this resistive network, then the voltage E can be increased beyond -30 v to

allow for the voltage drop across the recorder. For a 1000-ohm recorder, E would be -31 v to produce the proper full-scale reading. Since the counter can be set to 999, calibration is simple, and the recorder impedance need not be known.

To operate a 100-millivolt potentiometer recorder, an internal 100-ohm resistor is switched across the output terminal.

Standardizers (Electronic Switches)

Figure 7 is a detailed schematic of one of the electronic switches. For +185-v input (binary 0) Q₁ is turned off, Q₂ is on. The current through Q₂ would cause point A to be positive, but the clamping diode CR2 conducts and holds point A at a few tenths of a volt positive with respect to 0, say +0.5 v. For +65-v input (binary 1) Q₁ is on, Q₂ is off, and point A is clamped to voltage E by CR1. Again, the forward drop across CR1 causes about 0.5-v offset from E. Assume that E is -29 v. Then A will be either +0.5 v or -29.5 v. This 30-v swing is required for full output into zero load

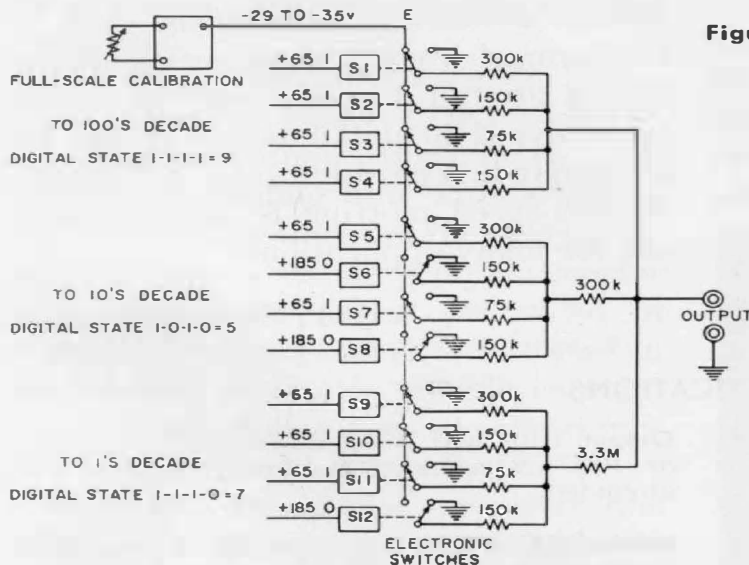

Figure 6. Simplified schematic diagram of the Converter.

Figure 7. Detailed schematic diagram of one of the electronic switches.

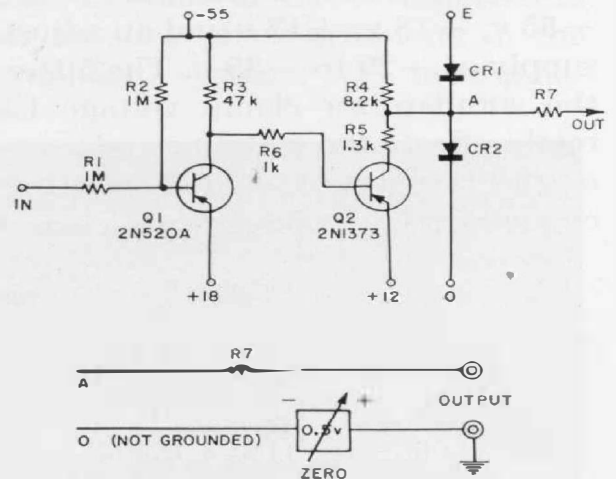

Figure 8. Offset voltage is connected in series with the output terminals.

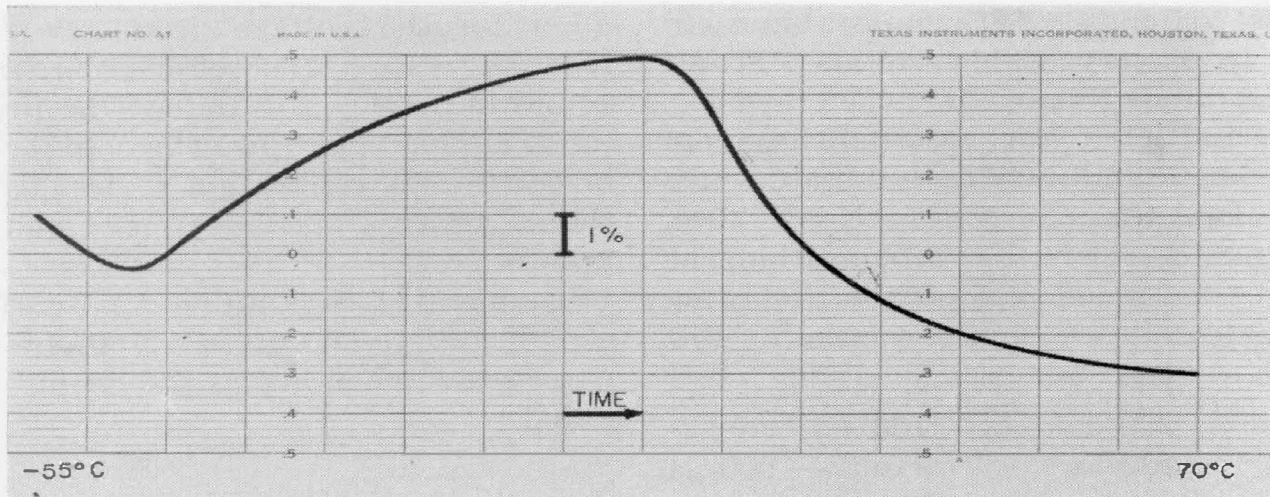

Figure 9. Capacitance-vs-temperature of a capacitor with high dielectric constant. The data were obtained by measuring the period of an RC oscillator.

impedance. To be able to ground one side of the recorder and to prevent current from flowing through it with the $+0.5\text{v}$ at A, an offset voltage is connected in series with the output terminals (see Figure 8). The common or low-potential side of the circuit (0) is not grounded to the chassis, but is at about -0.5v . Because the forward drop of the diodes varies about 2mv per $^{\circ}\text{C}$, temperature control was necessary. All critical elements are housed in a constant temperature oven.

Power Supply

There are four regulated voltages of -55v , $+18\text{v}$, $+12\text{v}$ and an adjustable supply of -29 to -35v . The latter (for the standardizer clamp voltage E) directly affects the stability and accuracy of the instrument, and, hence, critical components are temperature controlled.

The stability of this supply is better than 0.05% for line, load, and temperature changes. Temperature compensation reduces the warm-up drift to less than 0.5% so that in many applications no warm-up interval is required. The full 0.1% stability is obtained after about 30 minutes.

Applications

Figures 2, 3, and 9 illustrate a few of the many uses of the digital-to-analog converter. In all of these, it is an important advantage to have the data in the form of a continuous curve, rather than a printed digital record that must be analyzed in detail before it can be interpreted. The additional advantage of high-speed plotting is an important one for many applications.

— H. P. STRATEMEYER

SPECIFICATIONS

Data Input: BCD, weighted 1-2-4-2 or 1-2-2-4. Binary "1" $+90\text{v}$ max. Binary "0" $+150\text{v}$ min. Source impedance 500 kilohms, max. Input impedance $1\text{M}\Omega$. Can be driven from General Radio TYPE 1130-A Digital Time and Frequency Meter or TYPE 1131-P4 Storage Units. Digit selector switch selects any adjacent 3, or the last 2, of 4-decade input.

Output: 1 ma with 30-kilohm source impedance or 100 mv across 100 ohms. Positive side grounded.

Load: 2000 ohms maximum for 1 ma. 2000 ohms minimum, for 100 mv.

Linearity: $\pm 0.05\%$ of full scale.



Stability: $\pm .02\%$ for $\pm 15\%$ line. $\pm .03\%$ for ambient from 0-50C.

Warm-Up Drift: Less than .5% of full scale. Thermal equilibrium after 30 minutes.

Power: 100 to 130 (or 200 to 260) volts. 50 to 400 cps 30 watts maximum.

Accessories Supplied: Power cord, spare fuses,

cable to connect to TYPE 1130-A Digital Time and Frequency Meter.

Transistor Complement: One 2N1374, two each 2N1184, 2N1377, fourteen 2N520A, and twelve 2N1373.

Dimensions: Width 19, height $3\frac{1}{2}$, depth $13\frac{1}{2}$ inches (485 by 85 by 345 mm), over-all.

Net Weight: $16\frac{1}{4}$ pounds (7.4 kg).

Type		Code Word	Price
1134-AM	Digital-To-Analog Converter (Bench Model) ...	MOTTO	\$595.00
1134-AR	Digital-To-Analog Converter (Rack Mount).....	MINOR	595.00

A NEW, NARROW-RANGE DELAY LINE

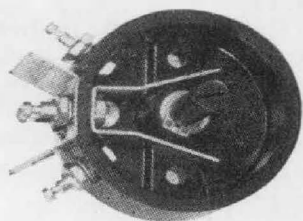

Figure 1. View of the Delay Line.

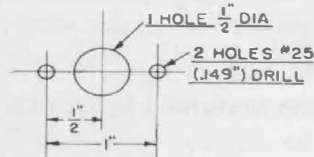

Figure 2. Mounting Dimensions.

There has arisen recently an important group of applications for variable delay lines with short delay ranges. These are used as radio-frequency phase shifters, usually as trimmers for phase adjustment. They have applications in radar, in computers, and in other pulse-operated equipment.

The TYPE 301-S104 Variable Delay Line, shown in Figure 1, has been designed for these applications. It is a small distributed-winding unit with a sliding tap for the adjustment of the delay. The winding is on a standard potentiometer base, whose dimensions are given in Figure 2. Precious metal wire is used in the winding to ensure reliable contact. Capacitive coupling between the terminals is minimized by shielding.

The pulse response of this delay line is shown in the oscillogram (Figure 3) which is taken from the screen of a Lumatron 112 Oscilloscope. The sweep

speed is 5 nanoseconds per centimeter. The photograph shows two sweeps, the first with the delay line set for minimum delay, and the second with the line set for maximum delay. Delay, rise time, baseline ripple, and pulse distortion can be measured from the photograph. Attenuation is low because of the short delay range and may differ slightly between units.

APPLICATIONS

Delay lines of this type are very useful in the various correlation techniques for improving signal-to-noise ratios in radar and space-probe communication links. Other applications include phase trimming for multiple-unit steerable-array (MUSA) antennas in the i-f channels and similar antenna phase trimming in the i-f amplifier systems of monopulse radars.

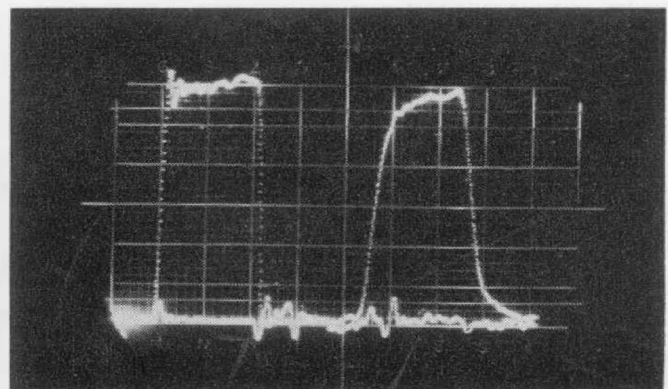

Figure 3. Pulse response of Delay Line.

There are many pulse applications for these narrow-range delay lines. A common one is the use as a patch-cable delay equalizer in a digital computer using short, fast-rise pulses. Others include the adjustment of delay in coincidence circuits of nuclear counters and the trimming of pulse coincidence in computer circuits. There are applications in

pulse-forming networks, and as substitutes for coaxial cables in various short-rise-time delay networks. One advantage of the wire-wound type of delay network as compared to coaxial cables is that one can adjust the delay both ways from a median setting, a process that is obviously quite difficult with cables.

— F. D. LEWIS

SPECIFICATIONS

- Delay Range:** 0 (approx) to 25 nanoseconds ($\pm 10\%$).
- Resolution:** 0.06 nsec.
- Characteristic Impedance:** 200 ohms $\pm 20\%$.
- Pulse Rise Time:** 2.4 nanoseconds (approx) at maximum delay.
- DC Resistance:** 5.5 ohms ($\pm 20\%$).

- Voltage Rating:** 1500 volts, peak, winding to ground.
- Dimensions:** (Body diameter) $1\frac{3}{4}$ by 2 by (thickness, exclusive of shaft) $\frac{15}{16}$ inches (45 by 51 by 24 mm); shaft diameter, $\frac{1}{4}$ inch (6.4 mm); shaft extension beyond body, $\frac{3}{4}$ inch (19 mm).
- Net Weight:** $1\frac{1}{2}$ oz (45 grams).

<i>Type</i>	<i>Code Word</i>	<i>Price</i>
301-S104 Variable Delay Line	NEEDY	\$48.00

NEW DISTRICT OFFICES

In September, the General Radio Company opened two new sales offices — Syracuse, New York, and Orlando, Florida, for the convenience of our many customers in these areas.

The Syracuse Office is managed by Leo J. Chamberlain, formerly of our New York District Office. The Syracuse address:

General Radio Company
 Pickard Building
 East Molloy Road
Syracuse 11, New York

Telephone: GLenview 4-9323

In Florida, the manager is John C. Held, formerly of the Washington District Office. The Orlando address:

General Radio Company
 113 East Colonial Drive
Orlando, Florida

Telephone: GArden 5-4671

Both men hold engineering degrees and have several years' experience with General Radio instruments, both at the factory and in the field. They and their staff are prepared to give prompt technical and commercial service to our customers in the busy industrial areas of upper New York State and Florida. Please feel free to make use of these new facilities if you are located in either of these areas.



J. C. Held



L. J. Chamberlain

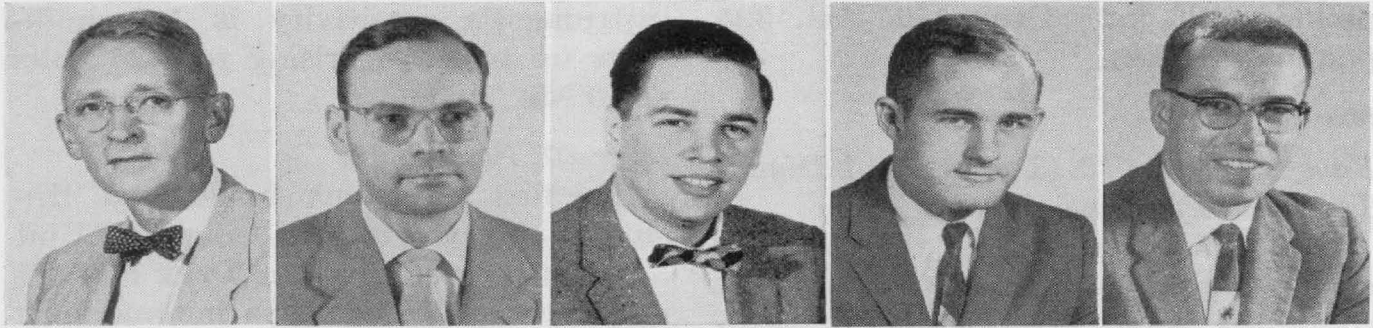

K. Adams

J. E. Snook

C. W. Alsen

J. P. Eadie

J. L. Lanphear

Other Personnel Changes in Our Sales Offices

Kipling Adams, formerly manager of our Philadelphia area office in Abington, Pa., has returned to our main office as Assistant to Sales Manager to aid in the administration of our growing number of district sales offices. His many years of sales experience in our district offices is a valuable asset in his new activity.

John E. Snook, who for several years has been a sales engineer in our Philadelphia Office, is now the manager. He is assisted by Carl W. Alsen who was

recently transferred to this office from our main office. Our Philadelphia office is responsible for sales in the important industrial states of Pennsylvania and southern New Jersey.

J. Peter Eadie has been transferred to our New York District Office from our main office at Concord, Mass. He is responsible for sales coverage in the Long Island area.

James L. Lanphear has recently been transferred from our main office to our Washington, D.C., area office located in Silver Spring, Maryland.

ERRATA

Several errors of omission and commission in past issues have recently come to our attention.

July-August, 1960

Page 5 (Tunnel-Diode Measurements)

Equation (1), last term in denominator of expression for G_c should be

$$\left(\frac{\omega L}{R}\right)^2 \left(1 - \frac{RR_s C}{L}\right)^2$$

November-December, 1960

Page 11, Figure 2. (Crystal Discriminator)

A ground was omitted from this diagram. Corrected diagram is shown here.

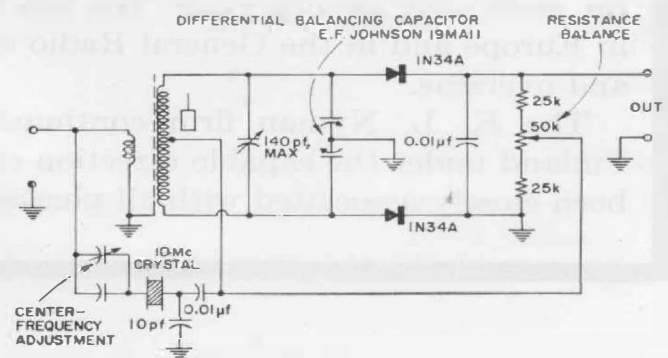

April, 1961

Page 14 (Type 1120 Frequency Standards)

Net weights given are too low. Corrected values are TYPE 1120-A, 275

pounds (125 kg); TYPE 1120-AH, 325 pounds (148 kg).

May, 1961

Page 14, Figure 12. (Type 1130-A Digital Time and Frequency Meter)

The timing diagram for the counting and storage decade is not too clear and contained some errors. The diagram shown herewith should be used.

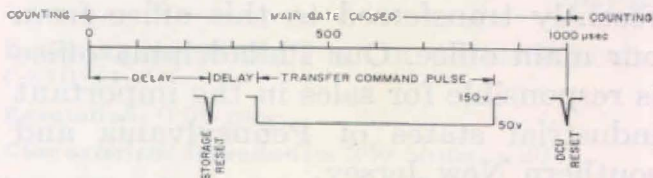

In the first column on this page, this time sequence is described. Item 1 should read: After a 250-μsec delay, the storage units are . . .

Page 19, Sensitivity Specification

The sensitivity as given is 0.25 volts rms. This is the worst case, and the

instrument's sensitivity is 100 millivolts up to 3 Mc, rising to 0.25 volts at 10 Mc.

Page 20, Price Table

The first two items should read "Including TYPE 1130-P1 Coupling Unit . . ." (Please note that the TYPE 1130-P1 is *not* a complete time-base unit and must be fed from an external oscillator.)

July, 1961

Page 9 (RC Null Circuits)

The tuning law of the circuit used in the TYPE 1232-A Tuned Amplifier and Null Detector and its dual is incorrect. It should read:

$$\omega_0 = \frac{1}{RC \sqrt{(1 + 2K) \alpha (1 - \alpha)}}$$

Page 10 (Transfer Voltage Ratio)

In the next to last sentence, ". . . (or a real Z_{12}) . . ." should read ". . . (or a real z_{21}) . . ."

K. L. NYMAN

Karl Lauri Nyman, of the firm K. L. Nyman, of Helsinki, died on August 27th. Mr. Nyman has represented the General Radio Company in Finland for more than twenty years. His loss will be keenly felt by his many friends in Europe and in the General Radio organization, both in the United States and overseas.

The K. L. Nyman firm continues as GR's exclusive representative in Finland under the capable direction of Mrs. Nyman who for many years has been closely associated with all phases of the firm's operation.

General Radio Company